

ST186

Structurally Glazed 186mm Framing System

- Available in Curtain Wall and Window Wall arrangements.
- Offsite prototype tested in a number of arrangements to:
 - AS/NZS 4284:2008 Testing of building facades
 - AS 2047:2014 Windows and external glazed doors in buildings
- Developed by a team of expert designers, manufacturers and installers specifically for the Australian market.
- Extruded and manufactured in Melbourne.
- Available as a thermally broken system.
- Fast lead times.
- Low carbon footprint.
- For system details please contact Spective.

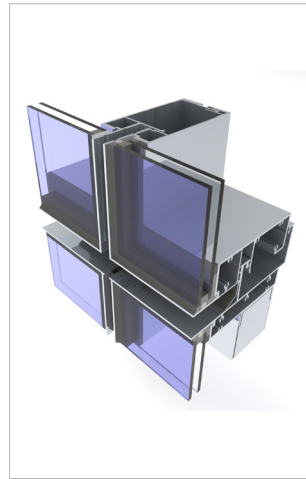

ST186 Curtain Wall



ST186 Window Wall

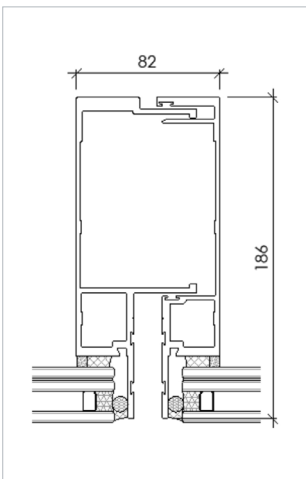

Standard mullion

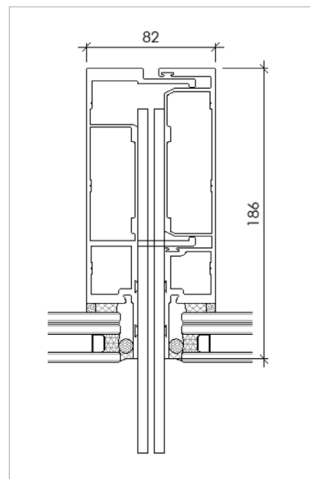

Heavy-duty (sunshade) mullion

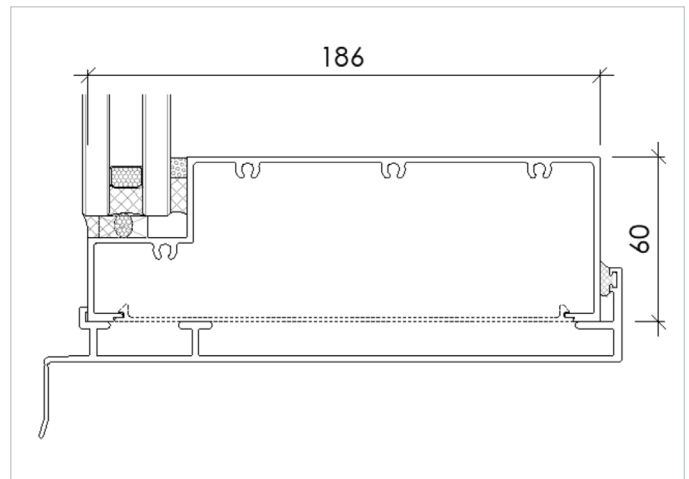

Subsill