

# SKY100

## Skylight

- Offsite prototype tested to:
  - AS/NZS 2047:2014 Windows and external glazed doors in buildings.
  - TN67 hard body, soft body, static load testing.
- Developed by a team of expert designers, manufacturers and installers specifically for the Australian market.
- Extruded and manufactured in Melbourne.
- Available as a thermally broken system.
- Fast lead times.
- Low carbon footprint.
- For system details please contact Spective.

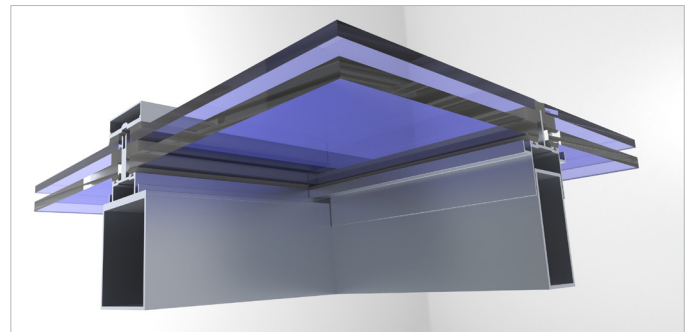
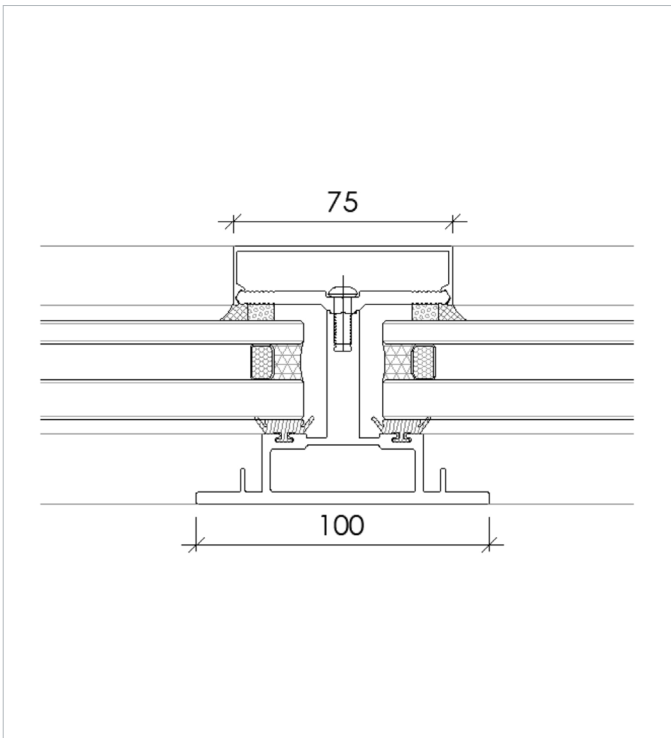

SKY100 Underside view

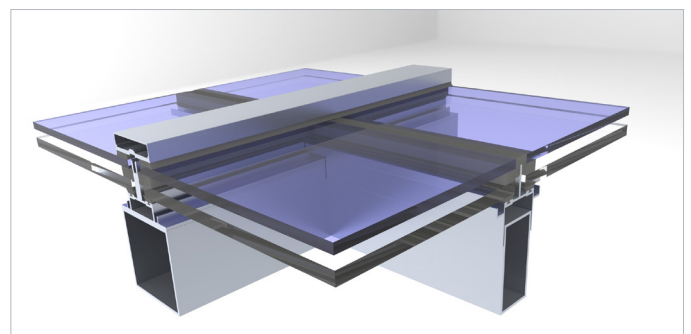

SKY100 Above view