

LS200

Double stage louver

- Offsite prototype tested to:
 - AS 4740:2000 Natural ventilators
- Developed by a team of expert designers, manufacturers and installers specifically for the Australian market.
- Extruded and manufactured in Melbourne.
- Available as a thermally broken system.
- Fast lead times.
- Low carbon footprint.
- For system details please contact Spective.

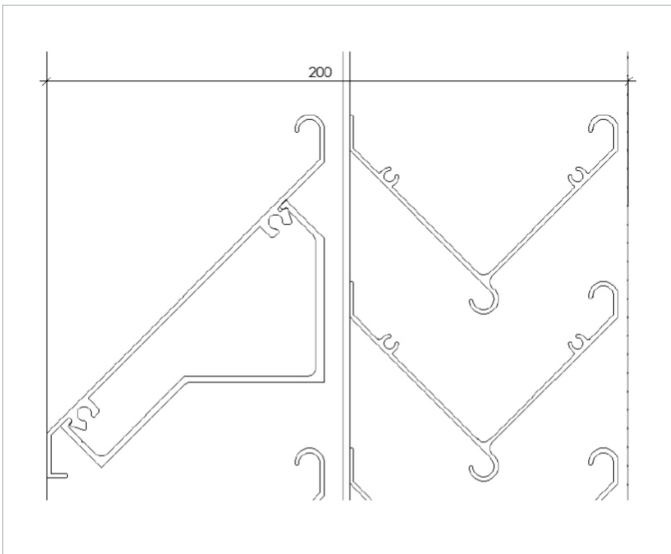

LS200 Double stage louver